

TRUCK MOUNTED CONCRETE PUMPS

H 37 5Z

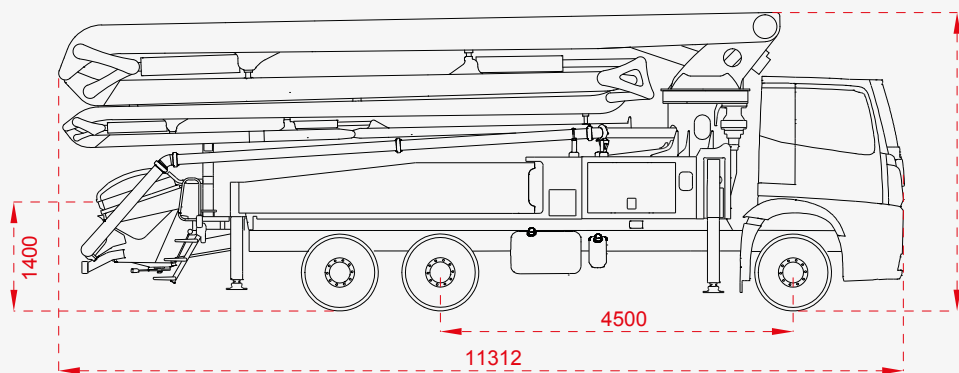

● TECHNICAL DETAILS



● SUPPORT LEGS DIMENSIONS

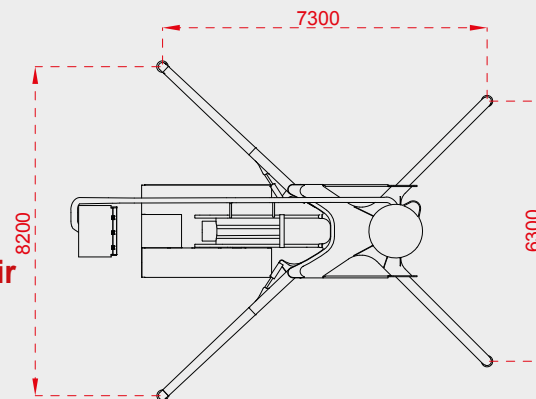

www.saghargostar-co.ir
@mr.pump_iran
+98 0912 8 584 584
+98 021 - 224 286 75/8

● PUMP GROUP

	Standard BST 37.14-5Z
Theo. Concrete Output (max) (Rod Side)	140 m ³ / h
Theo. Concrete Pressure (max) (Rod Side)	69 bar
Stroke	26 stroke / min
Concrete Cylinder Dimensions	230 mm x 2100 mm
Main Hydraulic Pump	A4 VG 180 (REXROTH)

● PUMP SPECIFICATIONS

Hopper Capacity	: 650 liter
Switching System	: Elect. Magn. Sensor
Concrete Valve	: S Valve System
Boom Pump	: A7V028 or A17F0032 (REXROTH)
Agitator Pump	: Included (ASC)

● STANDARD EQUIPMENTS

Smartstar Control System	: Included
Electric Box	: Water Proof and Computer Control
Proportional Remote Controller	: Included (HETRONIC)
End Hose	: 3 m
Water Pump	: Included, 4 m ³ /h
Water Tank Capacity (Material: Composite)	: 500 liter, 15 m hose with fittings
Lubrication System	: Hydraulic (LINCOLN and ALLFETT)

● OPTIONAL EQUIPMENTS

Driven by	: PTO or Gear Box
Vibrator	: Optional
Air Compressor	: Optional
Stability Control System	: Optional
End Hose Squeezer	: Optional
High Pressure Washing Pump	: Optional

● BOOM SYSTEM

Boom Type	: 5Z
Vertical Reach (max)	: 36,5 m
Horizontal Reach (max)	: 32,5 m
Boom Unfolding Height (min)	: 8,8 m
1. Boom Length	: 9,4 m
2. Boom Length	: 7,6 m
3. Boom Length	: 7,6 m
4. Boom Length	: 3,9 m
5. Boom Length	: 3,8 m
Boom Swing Speed	: 113 sec
Boom Swinging Angle	: 365°
Concrete Pump Diameter	: 5"

● SUPPORT LEG SYSTEM

Front Legs	: Diagonal Folding
Rear Legs	: Side Hydraulic Swing
Distance of Front Legs (max)	: 6,3 m
Distance of Rear Legs (max)	: 8,2 m

● BOOM WORKING DIAGRAM

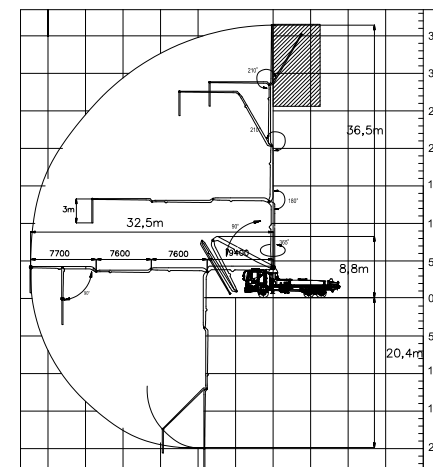

www.saghargostar-co.ir
 @mr.pump_iran
 +98 0912 8 584 584
 +98 021 - 224 286 75/8